

**L31171**  
**Rev. 11/05**

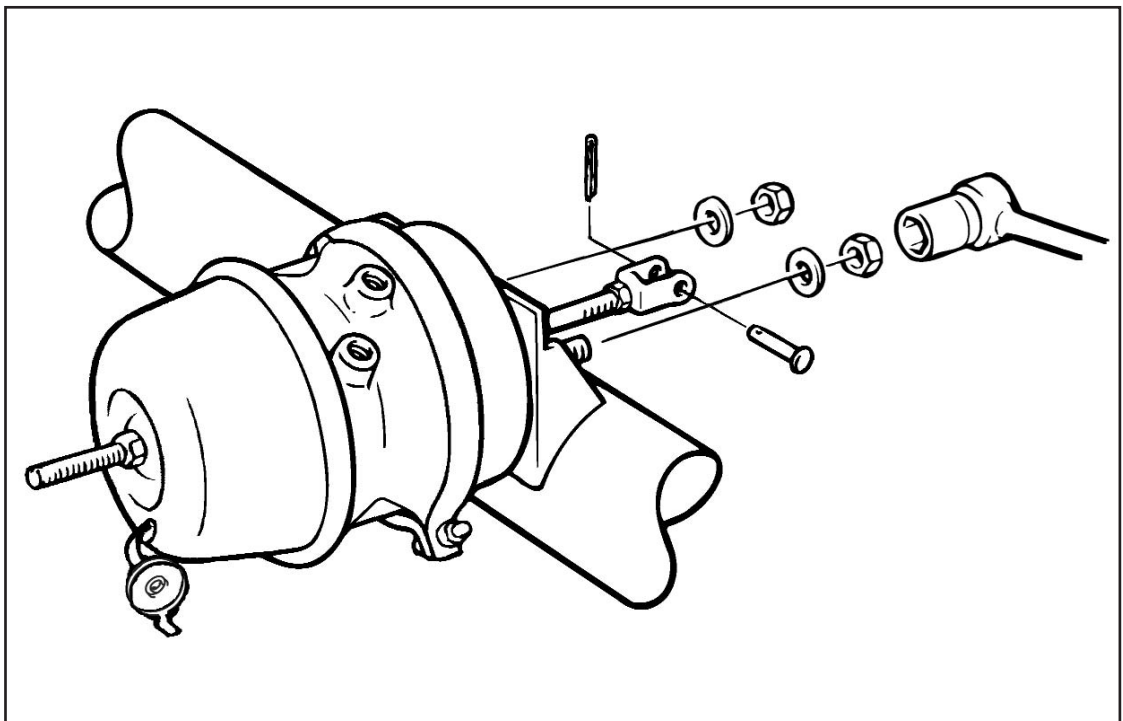

**Sealed Spring Brakes**  
**Life Seal® , Gold Seal® and Midland**  
**Installation Instructions**

---

# Contents

GENERAL SAFETY PRECAUTIONS .....	2-5	SPRING BRAKE DISARMING PROCEDURES .....	20
RECOMMENDED PREVENTATIVE MAINTENANCE .....	6	ORANGE ALERT STROKE INDICATOR OPERATION.....	21
GOLD SEAL/MIDLAND - MECHANICAL RELEASE OF SPRING BRAKE .....	7-9	DETERMINING WARRANTY STATUS .....	22
LIFE SEAL - MECHANICAL RELEASE OF SPRING BRAKE.....	10		
SEALED INSTALLATION INSTRUCTIONS COMBINATION SPRING BRAKES .....	11-15		
PIGGYBACK MODEL .....	16, 17		
ROTATING MOUNTING BOLTS, CLAMPS AND AIR PORTS.....	18		
SERVICE DIAPHRAGM REPLACEMENT .....	19		

Throughout this manual, you will notice the terms **“NOTE”**, **“IMPORTANT”**, **“WARNING”**, and **“DANGER”** followed by important product information. So that you may better understand the manual, those terms are defined below. The **▲** warns of the possibility of personal injury or death.

## **NOTE:**

*Is used as a reminder of an instruction where the concern deals with product integrity and has to do with installation, operation, maintenance or service and care of the product.*

## **IMPORTANT:**

*Used without the safety alert symbol, is used as a reminder of an instruction where the concerns deal with product integrity and have to do with installation, operation, maintenance or service and care of the product. It is intended to show that vehicle breakdown and/or expensive repair could result if the instruction is not followed.*

## **▲ WARNING:**

*Is used with an instruction for the purpose of showing that a safe practice must be adhered to or that an unsafe practice must be avoided, and that if proper precautions are not taken, personal injury could result.*

## **▲ DANGER:**

*Indicates a potentially hazardous situation which, if not avoided, may result in serious injury or death.*

# General Safety Precautions

**⚠ DANGER:** A spring brake contains a very powerful compression spring. Failure to comply with all of the following instructions may result in forceful release of the piggyback or spring chamber and its contents which could CAUSE DEATH, SEVERE PERSONAL INJURY AND/OR PROPERTY DAMAGE.

**IMPORTANT:** ALWAYS BLOCK WHEELS to prevent vehicle rollaway when performing any brake maintenance.

**⚠ DANGER:** Haldex DOES NOT recommend the rebuilding of any of its air brake actuator products. Nor does Haldex recommend the use of rebuilt Haldex air brake actuators.

- If spring brake shows structural damage DO NOT cage the spring and DO NOT attempt to service it. Replace the complete unit. To prevent severe personal injury when removing an uncaged spring brake from a vehicle, cut the service push rod making sure to relieve all force on it. After cutting the push rod, remove the spring brake from the vehicle, then disarm the spring brake using a suitable safety chamber (See Page 20 - Figure 36).
- Never strike any part of the spring brake with a hammer or any other heavy object; structural damage may result.
- Do not drop spring brake, as power spring may forcefully release.
- If air pressure is used to aid in the caging process, do not tighten the release tool more than finger tight. The air pressure must always be exhausted after the spring has been mechanically caged prior to any disassembly.
- On all Haldex Life Seal, Gold Seal and Midland Spring Brakes, the emergency diaphragm cannot be replaced. Replace the complete piggyback. (Follow instructions listed under "Mechanical Release" on Page 7-9 for Gold Seal/Midland brakes. Page 10 for Life Seal brakes. And "Piggyback Installation Instructions" on Pages 16 and 17).

**IMPORTANT:** It is recommended that a new service brake diaphragm be used when installing a new piggyback. DO NOT use a piloted diaphragm on the service side (a piloted "protrusion" diaphragm is designed to be used in the emergency spring chamber only). Use of a piloted diaphragm results in a reduction of stroke length.

Continued on next page

FIG 1 - Gold Seal/Midland Spring Brake

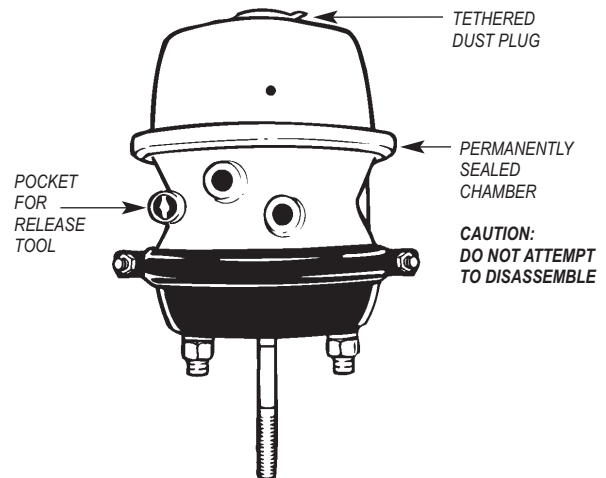
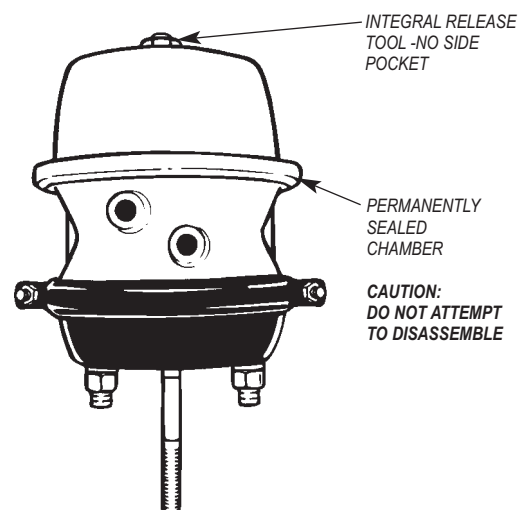

FIG 2 - Life Seal Spring Brake



## General Safety Precautions (Continued)

- Haldex manufactures a complete line of 3.0" (76mm) stroke brake actuators. In some cases these are referred to as "Long Stroke" (L). In other cases they are referred to as "Extra Long Stroke" (XL). To avoid confusion, please refer to Table 1 below.

**TABLE 1 STROKE MODELS**

2.5" (64MM) STROKE MODELS		3.0" (76MM) STROKE MODELS	
COMBINATION	PIGGYBACK	COMBINATION	PIGGYBACK
GC2424L	GP2424L	GC2430XL	GP2430XL
GC2430L	GP2430L	LC2430L	LP2430L
LC2430	LP2430	GC3030L	GP3030L
GC3030	GP3030	LC3030L	LP3030L
GC3036	GP3036		
LC3030	LP3030		

**⚠ WARNING: NEVER interchange 3.0" (76mm) stroke actuator components with 2.25" (57mm) or 2.5" (64mm) stroke components. Performance and stroke may be seriously affected.**

**⚠ WARNING: NEVER interchange spring brake manufacturers components. Performance and stroke may be seriously affected. Although spring brake manufacturers components look similar, they should never be interchanged.**

- When servicing 3.0" stroke actuators, it is imperative that strict attention is paid to the components. These air brake actuators have push rod stroke capabilities in excess of the standard 2.25" (57mm)\* or 2.5" (64mm) design. The serviceable components for these actuators are unique. They include the following:

\*2.5" stroke T-24 diaphragm may be used in 2.25" stroke T-24 service brake applications.

- 1) Service Diaphragm
- 2) Service Housing
- 3) Service Pushrod
- 4) Complete Piggyback

- These components are uniquely identified as "Long Stroke", "LS", or "3.0" (76mm) Stroke" on each component. The unique square bosses on the air inlet ports on the aluminum center body easily identify the spring brake as 3.0" (76mm) stroke (Figure 3).

- To aid in the identification of Long Stroke brakes being used on vehicles, Haldex has decals available (Figure 3A). These decals can easily be attached to the side of the vehicle.

Labels can be purchased from your local Haldex Distributor.

**FIG 3 - Gold Seal & Life Seal 3.0" (76mm) Stroke Spring Brake**

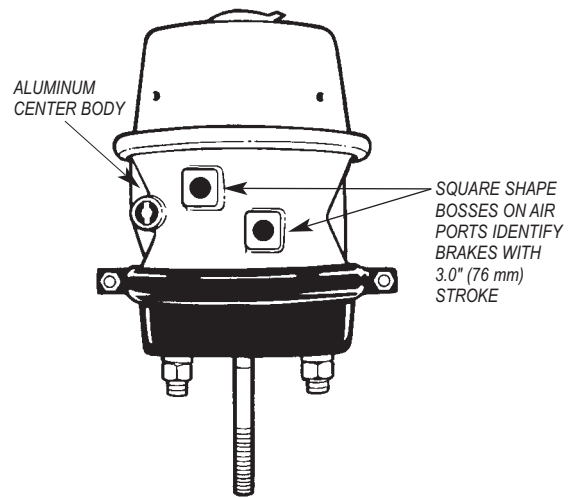

## General Safety Precautions (Continued)

FIG 3A - Long Stroke Brake Alert Decal

**L80033**

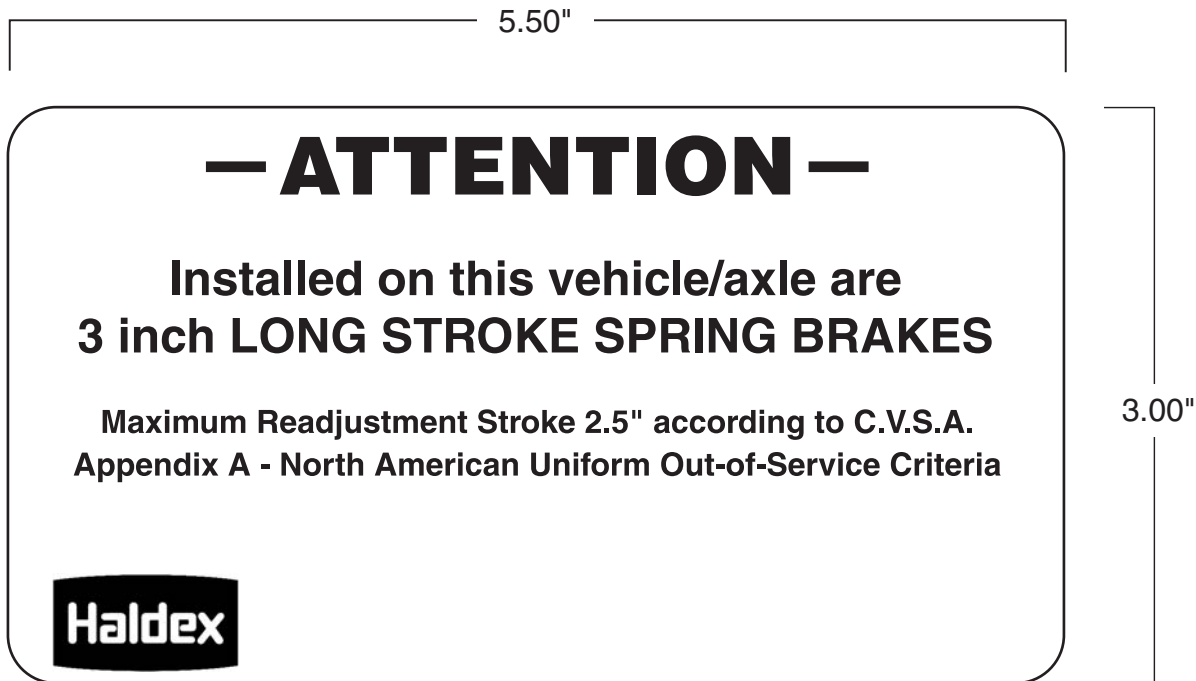

**L80034**



---

## Recommended Preventative Maintenance

- Preventative maintenance for Haldex Life Seal, Gold Seal and Midland combination spring brake models is recommended every three months or every 25,000 miles (40,000 km).

***IMPORTANT: ALWAYS BLOCK WHEELS to prevent vehicle rollaway when performing any brake maintenance.***

1. Check the conditions of the foundation brakes, including drums, shoes and linings, rollers, bushings, etc.
2. Check for structural damage of the Spring Brake, Brake Adjuster and S-Cam. Replace if necessary.
- 3a. Gold Seal and Midland Models:  
Apply the parking brake. Remove the Dust Plug from the rear of the chamber and physically inspect the condition of the parking spring. If the parking spring is broken, replace the Spring Brake with either a new piggyback unit or an entire unit. Please refer to Pages 16 and 17 for specific piggyback installation instructions or to Pages 11 thru 15 for combination installation instructions.

***IMPORTANT: ALWAYS replace dust plug after inspection.***

- 3b. Life Seal Models:  
Mechanically release the parking brake and follow the procedure listed on Page 10.
4. Apply the Service Brakes. Check the air lines and fittings for leaks. Check for proper torque according to Table 4, Page 13.
5. After allowing the brake drum to cool to room temperature, check for the correct spring brake stroke and verify proper installation. Proper installation can be verified by following the instructions listed on Page 15.

# Gold Seal/Midland - Mechanical Release of Spring Brake

**⚠ DANGER:** Read Pages 2-5 carefully. Do not attempt to mechanically release (cage) the spring on a spring brake if it shows structural damage. Caging the spring or disassembly of the chamber may result in the forceful release of the spring chamber and its contents which could CAUSE DEATH, SEVERE PERSONAL INJURY AND/OR PROPERTY DAMAGE. Remove complete spring brake and replace with new unit.

**⚠ DANGER:** DISARM spring chamber before discarding old brake. To disarm, use a suitable Safety Chamber (see Page 20). Failure to disarm assembly prior to disposal may, in time, result in spontaneous release of the spring chamber and its contents, which could CAUSE DEATH, SEVERE PERSONAL INJURY AND/OR PROPERTY DAMAGE.

## TO CAGE PARK BRAKE COMPRESSION SPRING (RELEASE PARK BRAKE)

**IMPORTANT:** ALWAYS BLOCK WHEELS to prevent vehicle rollaway when performing any brake maintenance.

1. Remove dust plug from release tool key hole in center of spring chamber (Figure 4).
2. Remove release tool assembly from side pocket of center body (Figure 4).
3. Insert release tool through key hole in chamber into the spring piston (Figure 5 Arrow A).
4. Turn release tool 1/4 turn clockwise (Figure 5 Arrow B).
5. Pull on release tool to ensure stud crosspin is properly seated in the spring piston.
6. Assemble release tool washer and nut on release stud, finger tighten only (Figure 5).

Continued on next page

FIG 4

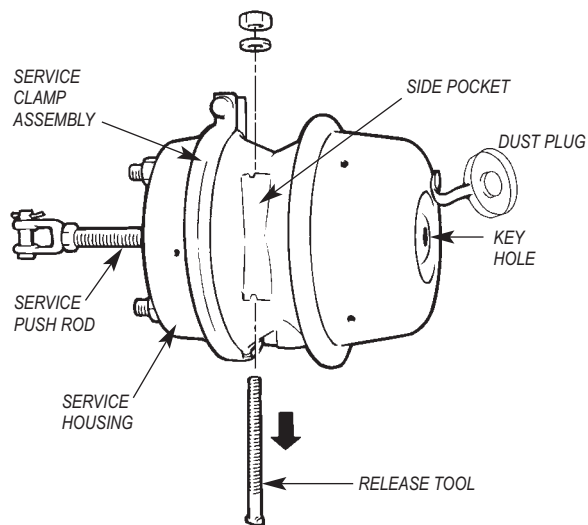
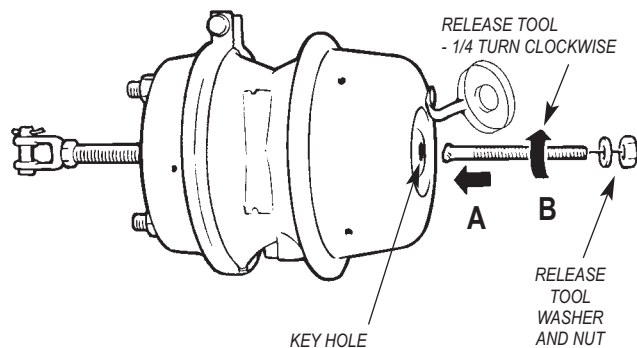

FIG 5



# Gold Seal/Midland - Mechanical Release of Spring Brake (Continued)

**⚠ DANGER:** The below listed instructions only apply when spring brake is not pressurized. If air pressure is used to compress the spring, do not tighten release tool more than finger tight. Torquing the release tool nut while the spring brake is pressurized can cause spring piston damage resulting in sudden release of the spring which could CAUSE DEATH, SEVERE PERSONAL INJURY AND/OR PROPERTY DAMAGE. Air pressure must be released after caging, prior to any disassembly.

7. a). Turn release tool nut clockwise with hand wrench (DO NOT USE HIGH SPEED AND/OR POWER DRIVEN IMPACT WRENCH) and make certain push rod is retracting (Figure 6).
7. b). This procedure will be made much easier if air pressure (100-120 PSIG; 6.6-8.0 BAR) is used to collapse the power spring before turning the release tool nut with a hand wrench. Proper caging will be complete when a slight resistance is felt after turning the release tool nut. Release the air pressure after caging prior to any disassembly.

**IMPORTANT:** Do not over torque release tool assembly. Over torquing release tool can cause spring piston damage.

**IMPORTANT:** To insure the power spring is fully caged, the release tool length (X dimension) (Figure 6) should measure as shown in Table 2.

FIG 6

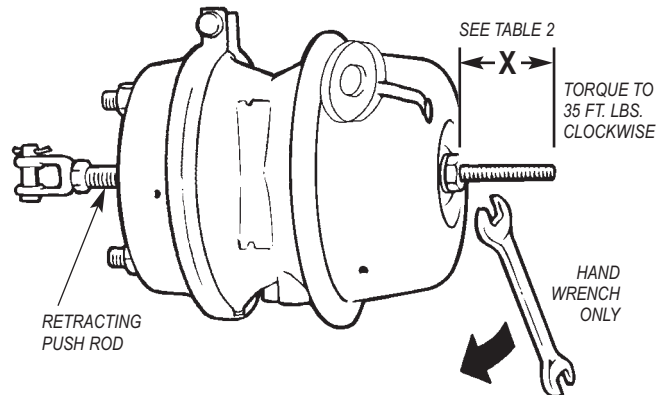

TABLE 2

MODEL	STROKE	X - MINIMUM
1624	2 1/4" (57mm)	2.9" (74mm)
2024	2 1/4" (57mm)	2.9" (74mm)
2424	2 1/4" (57mm)	2.9" (74mm)
2424	2 1/2" (64mm)	2.9" (74mm)
2430	2 1/4" (57mm)	2.9" (74mm)
2430	2 1/2" (64mm)	2.9" (74mm)
2430	3" (76mm)	3.4" (86mm)
3030	2 1/2" (64mm)	2.9" (74mm)
3030	3" (76mm)	3.4" (86mm)
3636	2 1/2" (64mm)	3.6" (91mm)
3636	3" (76mm)	2.4" (61mm)
3636	3" (76mm)	3.6" (91mm)

**NOTE:** If dimension of release tool (X dimension) length is less than the minimum measurement, then spring brake unit must be replaced.

Continued on next page

# Gold Seal/Midland - Mechanical Release of Spring Brake

## (Continued)

### TO UNCAGE PARK BRAKE COMPRESSION SPRING (APPLY PARK BRAKE)

1. Turn release stud nut counter clockwise with hand wrench (**DO NOT USE HIGH SPEED OR POWER DRIVEN IMPACT WRENCH**). This procedure will be made much easier if air pressure (100-120 PSIG; 6.6-8.0 BAR) is used to collapse the spring (Figure 7).
2. Remove caging tool nut and washer.
3. Push caging tool in, turn 1/4 turn counter clockwise and remove.
4. Place caging tool in pocket with T-head down and washer and nut up (this allows the washer to protect the pocket from corrosive elements while allowing the pocket to drain around the T-head (Figure 8).
5. Torque the nut to 5-8 ft. lb. (6.8-10.8 Nm).
6. Install dust plug in key hole. Insert the plug into the keyhole in the housing and push firmly until the plug is securely in place.
7. Lift edge of tether plug to be sure the plug is firmly in place.

**IMPORTANT: Always re-install tethered dust plug in caging tool key hole. Failure to do so will result in corrosion and foreign particle ingestion through the key hole which will void the warranty. Do not use excessive force when installing the plug. Excessive force may damage the plug and make it unusable.**

Replacement tether plugs can be purchased from your local Haldex Distributor.

FIG 7

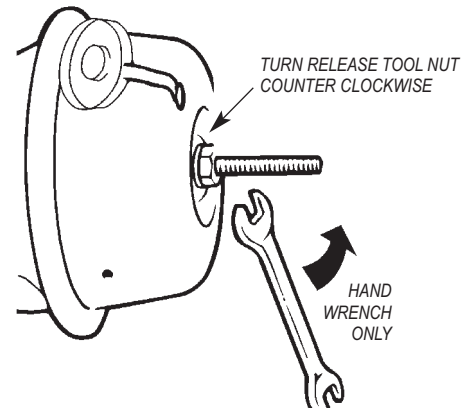
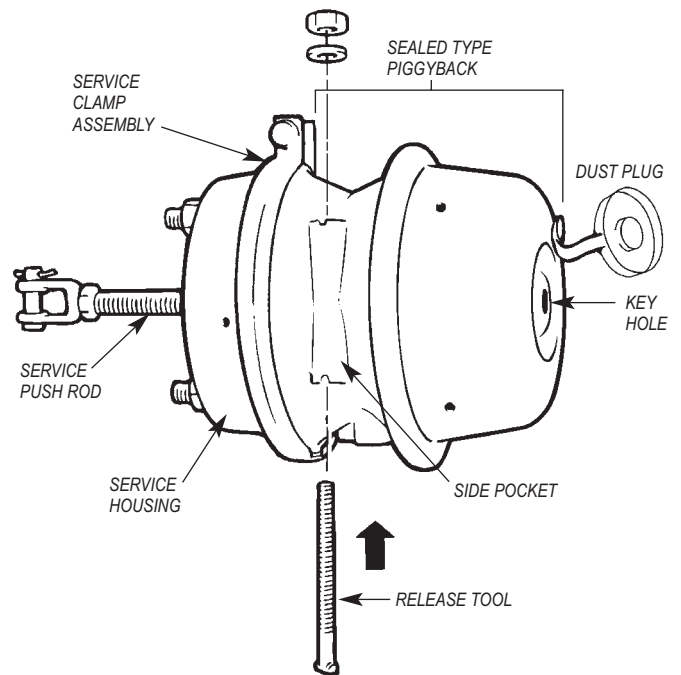

FIG 8



# Life Seal - Mechanical Release of Spring Brake

**⚠ DANGER:** The below listed instructions only apply when spring brake is not pressurized. If air pressure is used to compress the spring, do not tighten release tool more than finger tight. Torquing the release tool nut while the spring brake is pressurized can cause spring piston damage resulting in sudden release of the spring which could CAUSE DEATH, SEVERE PERSONAL INJURY AND/OR PROPERTY DAMAGE. Air pressure must be released after caging, prior to any disassembly.

**⚠ DANGER:** DISARM spring chamber before discarding old brake. To disarm, use a suitable Safety Chamber (see Page 20). Failure to disarm assembly prior to disposal may, in time, result in spontaneous release of the spring chamber and its contents, which COULD CAUSE DEATH, PERSONAL INJURY AND/OR PROPERTY DAMAGE.

## TO CAGE PARK BRAKE COMPRESSION SPRING (RELEASE PARK BRAKE)

**IMPORTANT:** ALWAYS BLOCK WHEELS to prevent vehicle rollaway when performing any brake maintenance.

**IMPORTANT:** Do not over torque release tool assembly. Over torquing release tool can cause spring piston damage. Life Seal S-Cam type 55 ft. lb. (74Nm) Maximum, Counter Clockwise.

1. a). Turn release tool nut counter clockwise with hand wrench (**DO NOT USE HIGH SPEED AND/OR POWER DRIVEN IMPACT WRENCH**) and make certain push rod is retracting (Figure 11).
1. b). This procedure will be made much easier if air pressure (100-120 PSIG; 6.6-8.0 BAR) is used to collapse the compression spring before turning the release tool nut with a hand wrench. Proper caging will be complete when a slight resistance is felt after turning the release tool nut. Release the air pressure after caging prior to any disassembly.

**IMPORTANT:** To ensure the power spring is fully caged, the release tool length (X dimension) (Figure 11) should measure as shown in Table 3.

## TO UNCAGE PARK BRAKE COMPRESSION SPRING (APPLY PARK BRAKE)

1. Turn release tool nut clockwise with hand wrench (**DO NOT USE HIGH SPEED OR POWER DRIVEN IMPACT WRENCH**). This procedure will be made much easier if air pressure (100-120 PSIG; 6.6-8.0 BAR) is used to collapse the spring.
2. Turn release tool nut until contact is made with the chamber. Torque to 55 ft. lb. (74 Nm). Torque value is stamped on chamber (Figure 12).

FIG 11

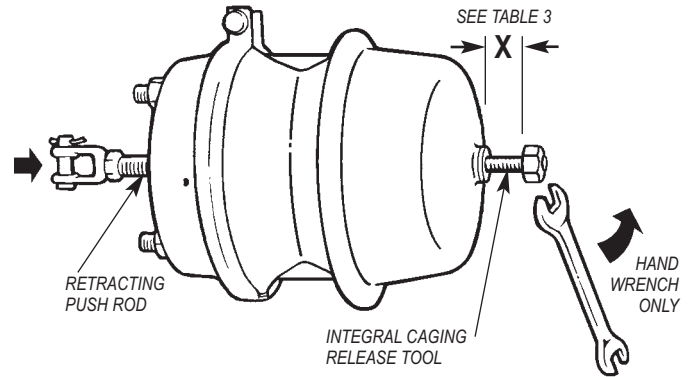
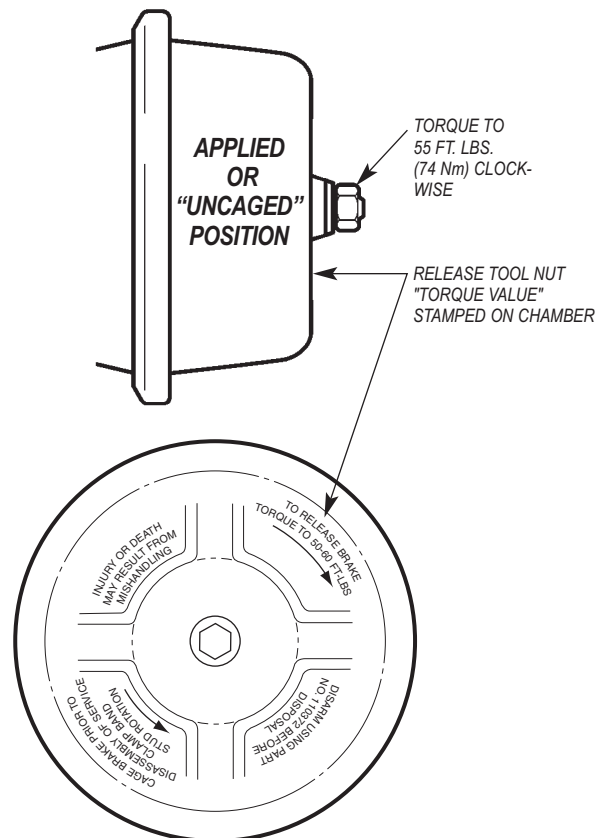

TABLE 3

CHAMBER TYPE	STROKE	X - MINIMUM	X - MAXIMUM
30	2 1/2" (64mm)	2.40" (61mm)	2.56" (65mm)
30LS	3" (76mm)	2.90" (74mm)	3.06" (78mm)

**NOTE:** If dimension of release tool (X dimension) length is less than the minimum measurement, then spring brake unit must be replaced.

FIG 12



# Combination Spring Brake Installation Instructions

## INSTALLATION PREPARATION

**IMPORTANT:** Spring brake must be caged prior to performing installation procedures. If brake is not caged, follow steps on Pages 7-10 for safety instructions and mechanical release of spring brake.

**NOTE:** In an effort to maximize the life of Haldex spring brakes, Haldex recommends the following brake mounting guidelines when installing spring brakes on your vehicle(s).

## CUT PUSH ROD TO CORRECT INSTALLATION LENGTH

**IMPORTANT:** Before installing a new combination spring brake, it is necessary to determine the correct service push rod length to ensure proper alignment for efficient operation of the spring brake.

**NOTE:** Units are furnished with a universal fully threaded push rod and must be cut to the correct length.

**IMPORTANT:** Place blocks under wheels to prevent vehicle rollaway before removing spring brake actuators.

**NOTE:** If spring brake unit being replaced is not available to take measurements from, follow the procedures listed under Step 5, Page 12.

1. **Remove worn or non-functional spring brake unit from vehicle:** Determine manufacturer and model of unit to be replaced. Refer to that manufacturer's service manual for caging and removal instructions.
2. Make sure the spring chamber of the removed actuator is fully released (power spring caged) and the service brake push rod is fully retracted to zero stroke position (i.e. brake fully released).
3. Measure and record the "J" and "K" dimensions from unit to be replaced (Figure 13).
  - "J" dimension = The dimension from bottom of actuator to end of piston rod.
  - "K" dimension = The dimension from bottom of actuator to centerline of clevis pin.
4. Take measured J" dimension (Figure 13) from the **removed** unit and mark push rod of **new** unit to be cut.

Continued on next page

FIG 13

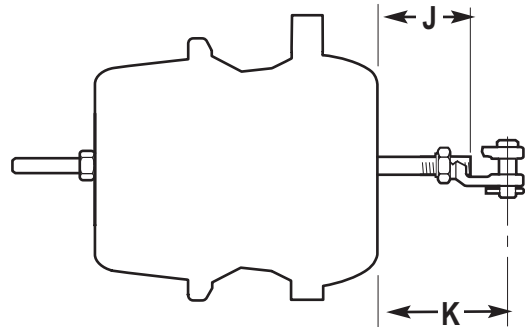
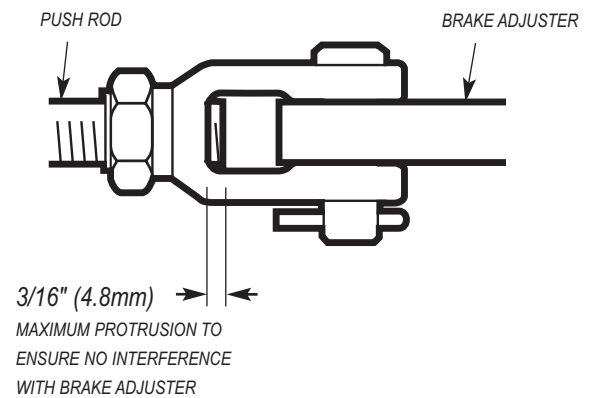

FIG 14



# Combination Spring Brake Installation Instructions (Cont'd)

**NOTE:** Step 5 lists the procedures to determine correct push rod length when the spring brake being replaced is not available. Move ahead to Step 6 if correct push rod length is already determined.

- To determine the correct push rod length of the brake to be installed, measure the "B" dimension as shown (Figure 15) and subtract the setup stroke as listed in Table 5 (Page 15). With the spring brake fully caged: "B" minus Setup Stroke = Push Rod Length including Clevis. (Figure 16)

**NOTE:** Setup stroke is only to establish push rod length. (See Step 6 on Page 14).

**EXAMPLE:**

For a typical Type 30 spring brake, if "B" (Figure 15) = 5.0 inches, setup stroke = 1 1/2 inches (Table 5, Page 15). The push rod length from mounting face to centerline of main clevis pin should measure: 5 minus 1 1/2 = 3 1/2 inches. with the spring brake caged. (Figure 16)

- Before marking push rod to be cut on **new** unit, be sure the spring chamber is caged and the push rod is fully retracted to the zero stroke position. **Refer to mechanical release instructions:** Pages 7-9 for Gold Seal brakes. Page 10 for Life Seal brakes.

**NOTE:** When determining the push rod cut-off length, the length of the threaded rod protruding between the clevis legs must not exceed 3/16" (4.8mm) to ensure no interference with the operation of the brake adjuster (Figure 14).

- Thread clevis jam nut past the mark on push rod. Align bottom edge of nut with mark to use as a guide for cutting. Use a sharp hack-saw and cut push rod on the mark.
- After cutting rod, thread jam nut off to clean up threads.

FIG 15

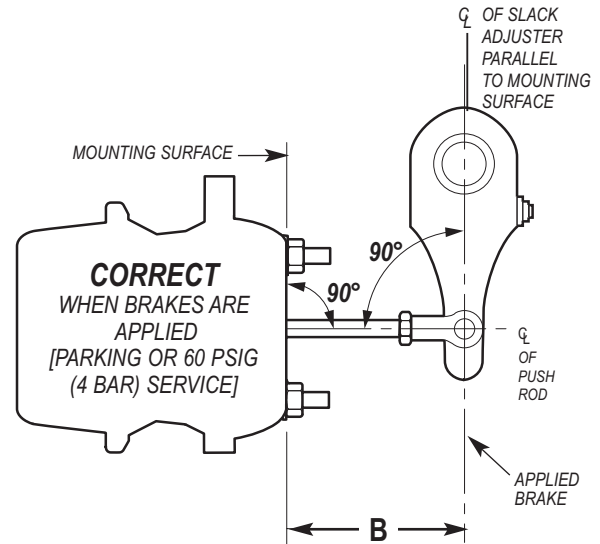
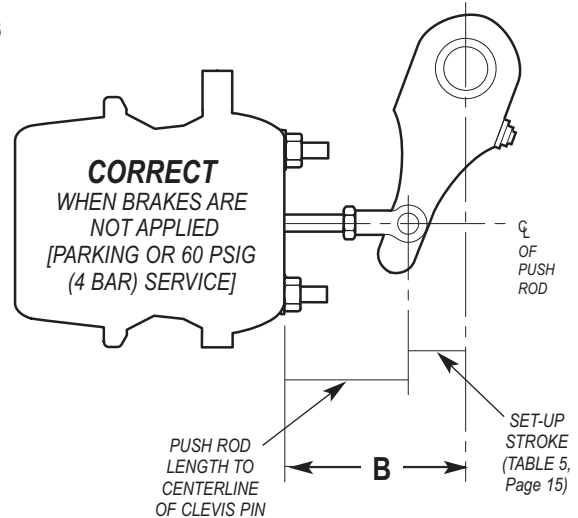

FIG 16



# Combination Spring Brake Installation Instructions (Cont'd)

## MOUNTING SPRING BRAKE TO MOUNTING BRACKET

When attaching spring brakes to mounting brackets the following checks and instructions should be performed:

1. Mounting brackets must be inspected to assure that bracket surface is free from debris, burrs, cracks, weld spatter and is flat within 1/64" (.4mm) (Figure 17).
2. Attach spring brake directly to mounting bracket on axle. Fasten with mounting hardware (Figure 17). Torque to specifications listed in Table 4 below.

**IMPORTANT:** When mounting a spring brake to a horizontal axle bracket, as shown in Figure 17, the bracket must meet the minimum contact area (Figure 17A).

When the spring brake mounting bracket requires the studs to be in the vertical position (rotated 90° from horizontal), the contact area can be slightly less than the minimum contact area for horizontal mount.

**IMPORTANT:** Always mount brake chamber directly to bracket, if a reinforcement plate is necessary, follow the guidelines for plate attachment below. **DO NOT insert spacers, washers or shims between mounting bracket and brake housing.** (Figure 17) Consult the bracket manufacturer for your application to determine if a reinforcement plate is necessary.

**DO NOT** mount spring brake in a vertical position. The spring brake must be mounted within 45 degrees of horizontal (Figure 18A).

**NOTE:** In some cases it may be necessary to rotate air ports and/or clamp bands for proper clearance and installation on vehicle. (See Page 18 for rotation instructions.)

## REINFORCEMENT PLATE ATTACHMENT GUIDELINES

When attaching a reinforcement plate to the brake mounting bracket face the following guidelines must be followed:

1. Attach .25" (6mm) steel plate 7" x 7" (178mm x 178mm) square, to brake mounting bracket face. Secure with (2) 5/8" or M16 bolts, washers and nuts, and torque to 50 ft. lb. (67.5 Nm) (Figure 18).
2. Weld reinforcement plate to brake mounting bracket (See Figure 19) for suggested weldment locations. For exact location and weld size, refer to axle manufacturer's guidelines. Allow welds to cool and remove bolts (Figure 19, Page 14).
3. Attach spring brake directly to new reinforcement plate. Fasten with mounting hardware (Figure 20, Page 14). Torque to specifications listed in Table 4 below.

**TABLE 4 INSTALLATION TORQUE VALUES**

	TORQUE
Mounting Hardware	130-150 lb. ft. (177-203 Nm)
Jam Nut	15-25 lb. ft. (20-34 Nm)
Port Plug or Reducer	15-20 lb. ft. (20-27 Nm)
Air Fittings	25-30 lb. ft. (34-40 Nm)
LIFE SEAL - Release Tool Nut	55 lb. ft. (74 Nm)
GOLD SEAL/MIDLAND - Release Tool Nut	25-35 lb. ft. (34-47 Nm)
GOLD SEAL/MIDLAND - Release Tool Nut (in side pocket)	5-8 lb. ft. (7-11 Nm)
Carriage Bolt Nuts (for clamps)	20-30 lb. ft. (27-40 Nm)

Continued on next page

FIG 17

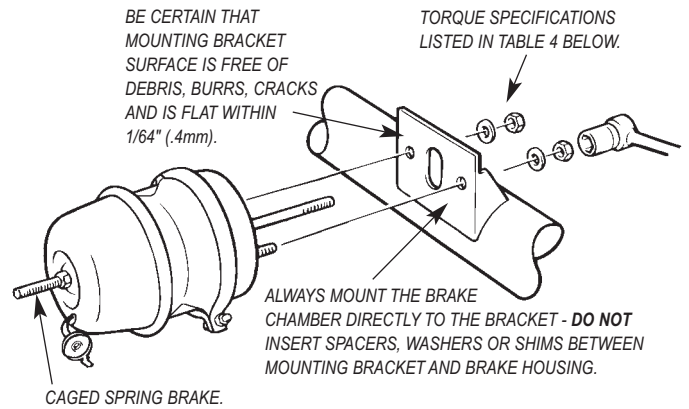

FIG 17A

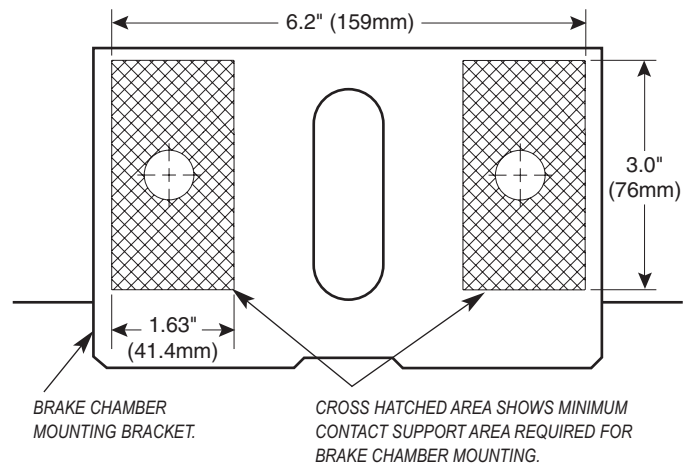

FIG 18

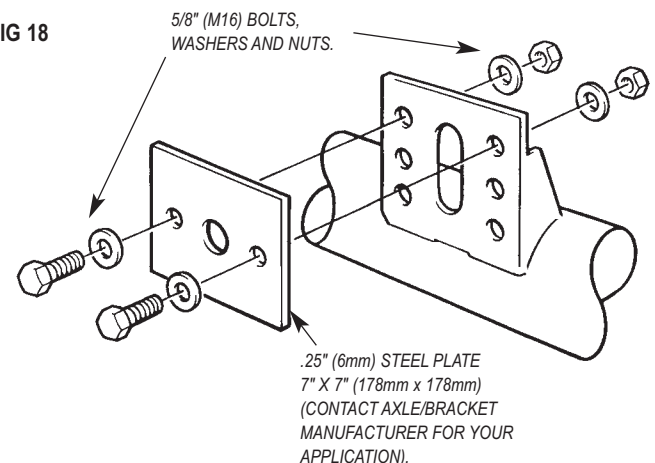
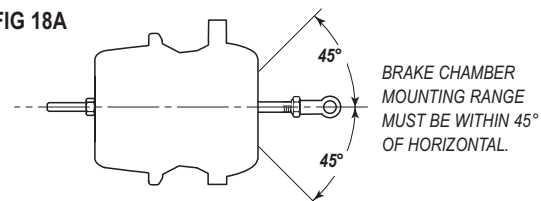

FIG 18A



# Combination Spring Brake Installation Instructions (Cont'd)

## ATTACH CLEVIS AND AIR LINES

1. Thread jam nut back onto the push rod a sufficient length to allow assembly of the clevis.
2. Thread clevis onto the push rod. Clevis from removed unit may be reused provided clevis pin hole is not worn. Adjust clevis to the same "K" dimension as measured from the removed unit (Figure 13, Page 11).
3. Hold clevis to prevent it from turning and tighten jam nut against clevis to torque specifications. (See Table 4, Page 13 for Installation Torque Values). The clevis must be adjusted so that it has full thread engagement on the push rod (from flush to 3/16" (4.8mm) protrusion). (Figure 14, Page 11).
4. Connect the service and emergency air line to the proper air ports. Torque to specifications listed in Table 4, Page 13.
5. Connect clevis to the slack adjuster using clevis and cotter pins, and uncage the spring brake. **Refer to uncaging procedures:** Pages 7-9 for Gold Seal and Midland brakes. Page 10 for Life Seal brakes.

**IMPORTANT: If push rod is not long enough to reach brake adjuster mounting hole, DO NOT physically pull push rod out to reach mounting hole.**

6. Adjust the brake adjuster to the listed setup stroke (See Table 5, Page 15). (Figure 22)

Continued on next page

FIG 19

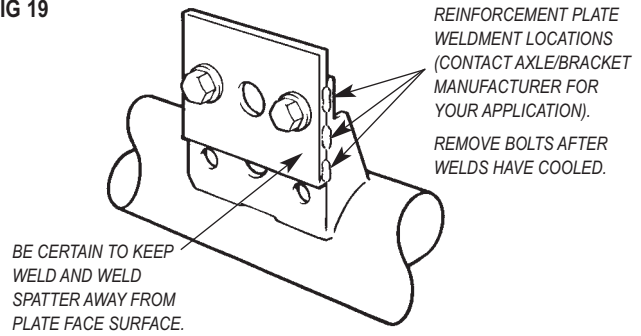

FIG 20

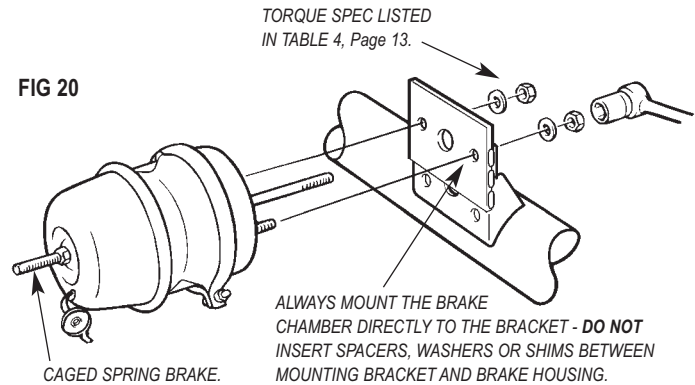

FIG 21

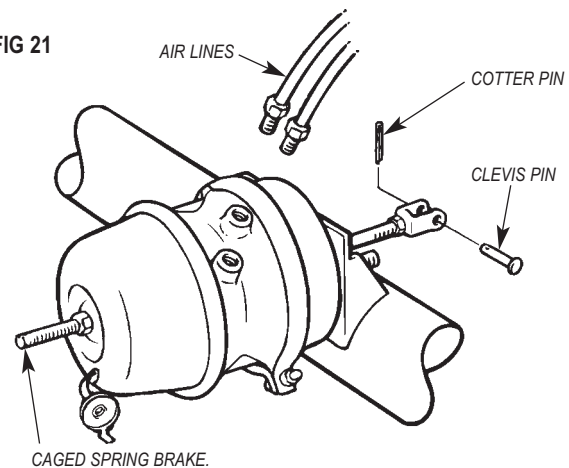

FIG 23

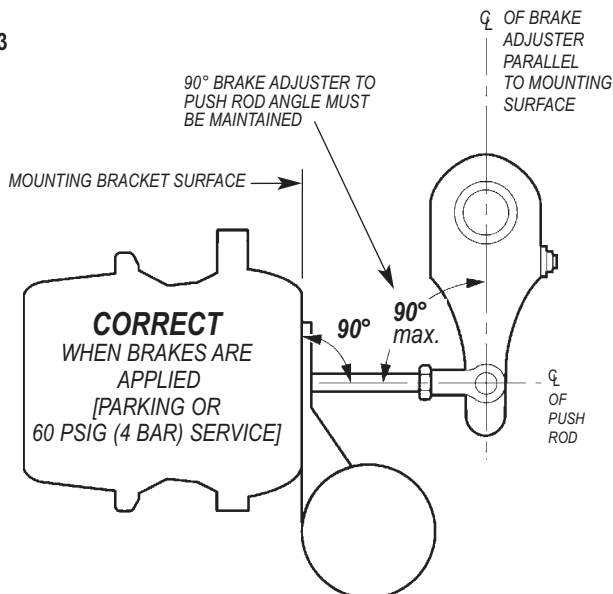
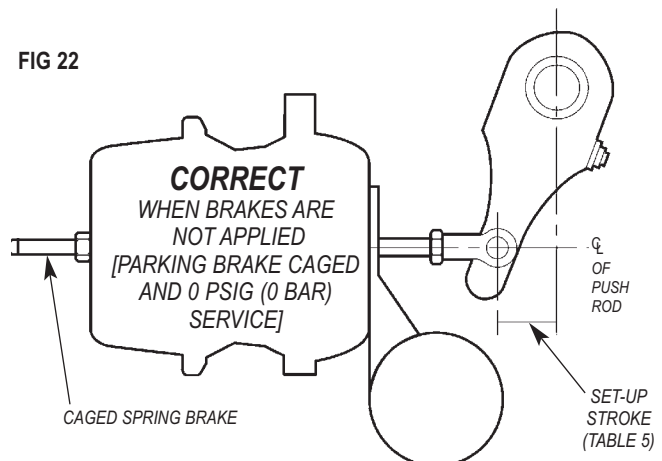

FIG 22



# Combination Spring Brake Installation Instructions (Cont'd)

## VERIFY PROPER INSTALLATION

- With the brake applied, the following conditions must occur:
  - push rod 90° to the centerline of slack adjuster; b.) push rod 90° to the mounting face of the spring brake. (Figure 23, Page 14).

**TABLE 5 STROKE VALUES**

CHAMBER TYPE	AVAILABLE STROKE	RECOMMENDED CHAMBER STROKE RANGE		SET-UP STROKE APPLIED BRAKE <sup>‡</sup>
		MINIMUM	MAXIMUM	
9	1-3/4" (44mm)		1-3/8" (35mm)	1" (25mm)
12	1-3/4" (44mm)		1-3/8" (35mm)	1" (25mm)
16	2-1/4" (57mm)		1-3/4" (44mm)	1-3/8" (35mm)
16	2-1/2" (64mm)		2" (51mm)	1-1/2" (38mm)
20	2-1/4" (57mm)	(Should be as short a stroke as possible without brake dragging)	1-3/4" (44mm)	1-3/8" (35mm)
20	2-1/2" (64mm)		2" (51mm)	1-1/2" (38mm)
20**	3" (76mm)		2-1/2" (64mm)	1-3/4" (44mm)
24	2-1/4" (57mm)		1-3/4" (44mm)	1-3/8" (35mm)
24	2-1/2" (64mm)		2" (51mm)	1-1/2" (38mm)
24**	3" (76mm)		2-1/2" (54mm)	1-3/4" (44mm)
30	2-1/2" (64mm)		2" (51mm)	1-1/2" (38mm)
30**	3" (76mm)		2-1/2" (64mm)	1-3/4" (44mm)
36	3" (76mm)		2-1/4" (57mm)	1-3/4" (44mm)

\* Stroke length measured by applying parking brake or 60 PSIG (4 Bar) service brake application

\*\* Long Stroke

‡ Typical setup stroke values

**NOTICE:** For special applications consult vehicle, brake or brake adjuster manufacturers.

**IMPORTANT: Incorrect push rod brake adjuster setup will result in improper brake operation.**

- If the setup results in the condition depicted in Figure 24 or Figure 25, the spring brake is misaligned and must be corrected by one or more of the following:

Figure 24 a.) shorten push rod, b.) align spring brake on mounting bracket, c.) mount clevis in proper brake adjuster hole.

Figure 25 a.) lengthen push rod, b.) align spring brake on mounting bracket, c.) mount clevis in proper brake adjuster hole.

If misalignment cannot be corrected, consult with foundation brake manufacturer for verification of correct mounting bracket position.

- Once the spring brake and push rod are set properly (Figure 23, Page 14), release the brakes and follow vehicle manufacturer's instructions for brake adjustment.

**IMPORTANT: After installation, check for proper emergency operation, service operation and brake adjustment.**

FIG 24

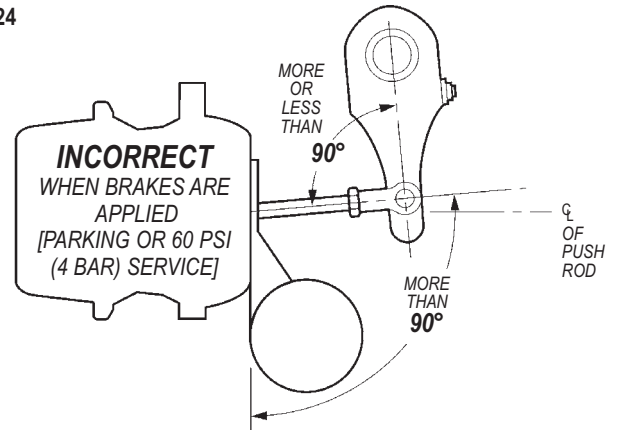
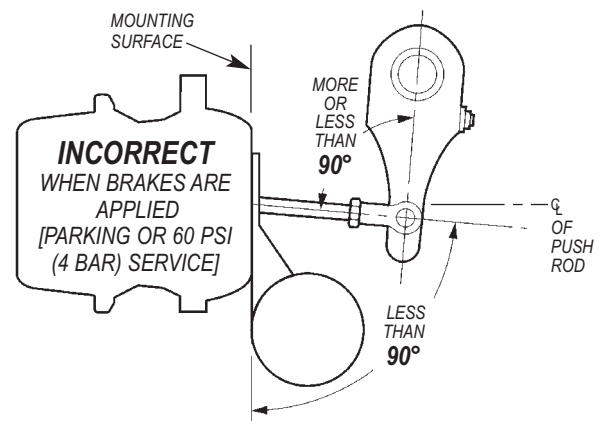

FIG 25



# Piggyback Installation Instructions

## TO REMOVE PIGGYBACK FROM SERVICE HOUSING

1. Refer to mechanical release instructions: Pages 7-9 for Gold Seal/Midland brakes. Page 10 for Life Seal brakes.

**⚠ WARNING: Failure to comply with all instructions for mechanical release may result in the forceful release of the spring which COULD CAUSE DEATH, SEVERE PERSONAL INJURY AND/OR PROPERTY DAMAGE.**

2. If vehicle air pressure was used to aid in the caging process, exhaust the air pressure.
3. To prevent sudden release of service housing assembly and to facilitate rotation of air ports or mounting studs, the service push rod should be prevented from retracting by clamping the service push rod in place with vise grip pliers as shown (Figure 28a/b).
4. Disconnect the airlines from the air ports on the center body.
5. Remove service clamp assembly (Figure 28a/b).

**IMPORTANT: DO NOT bend the clamp assembly when removing.**

## TO INSTALL PIGGYBACK ON SERVICE HOUSING

1. If piggyback is not caged, follow steps on Pages 7-9 for Gold Seal/Midland brakes. Page 10 for Life Seal brakes.

**⚠ WARNING: Failure to comply with all instructions for mechanical release may result in the forceful release of the spring which could CAUSE DEATH, SEVERE PERSONAL INJURY AND/OR PROPERTY DAMAGE.**

2. Before installing piggyback on existing non-pressure housing, inspect the clamp assembly, the service return spring, the service push rod and non-pressure housing. If any structural damage is noted, replace with new parts.
3. Wipe the surface of the service push rod clean of any oil, grease or dirt. Check to see that the bottom most vent holes in the housing are not plugged.

**IMPORTANT: It is recommended that a new service brake diaphragm be used when installing a new piggyback. DO NOT use a piloted diaphragm on the service side (a piloted "protrusion" diaphragm is designed to be used in the emergency spring chamber only). Use of a piloted diaphragm results in a reduction of stroke length.**

4. Place the new service diaphragm in center body (as shown) and center the housing over the diaphragm and adapter lip (Figure 29).
5. Ensure that diaphragm is properly seated between the center body and housing lip and that the air ports are in the desired positions. When reinstalling the one-piece service clamp assembly (Figure 28a), torque the carriage nut to specifications listed in Table 4, Page 13. When reinstalling the two-piece service clamp assembly (Figure 28b), tighten each nut equally, alternating every other turn. Torque each carriage nut to specifications listed in Table 4, Page 13. **DO NOT strike clamp or unit with a hammer.**

FIG 28a

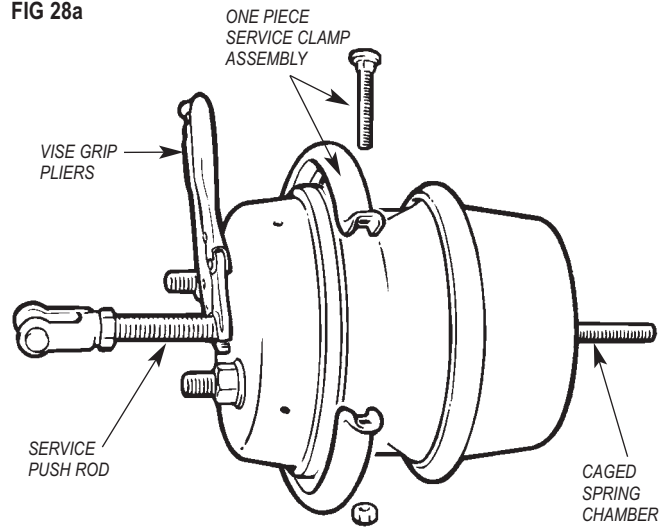

FIG 28b

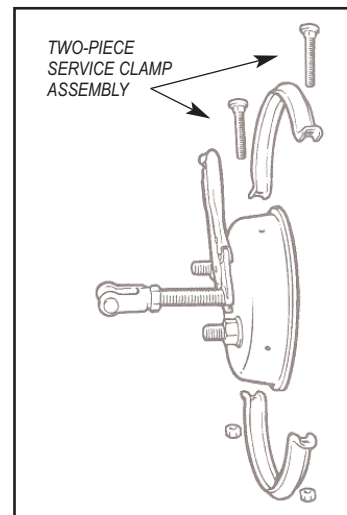
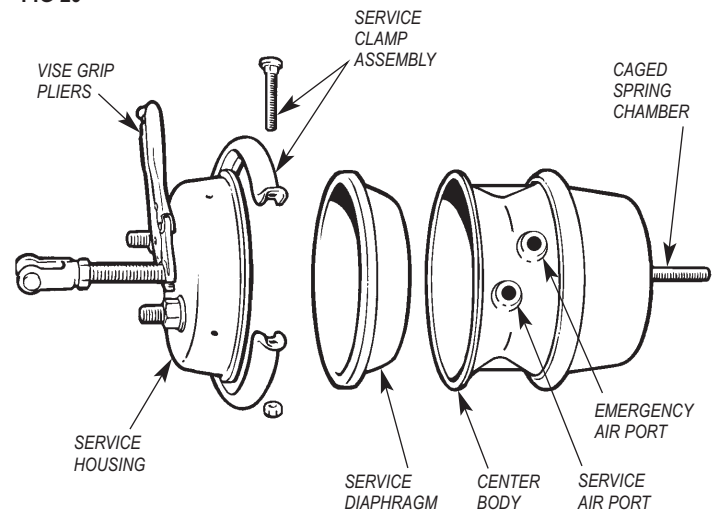

FIG 29



Continued on next page

---

## Piggyback Installation Instructions (Continued)

6. Check carriage bolts and clamp assembly for proper seating around the center body and housing lip, and remove vise grip pliers previously clamped around the service push rod to prevent it from retracting.
7. Reconnect the air lines to the air ports on the center body, making sure to connect the proper lines to the service and emergency ports (*Figure 29*). Torque to specifications listed in Table 4, Page 13.
8. Apply a maximum of 120 PSIG (8 BAR) air to the service port and check diaphragm seal for leakage by applying a water and soap solution to the service clamp area. (*No leakage allowed*).
9. Uncage park brake power spring. Refer to uncaging instructions: Pages 7-9 for Gold Seal/Midland brakes. Page 10 for Life Seal brakes.

***IMPORTANT: After reassembly, check for proper emergency and service brake operation. For brake adjustment, follow vehicle manufacturer's instructions.***

# Rotating Mounting Bolts, Clamps and/or Air Inlet Ports

## TO ROTATE SERVICE HOUSING MOUNTING STUDS

1. For Mechanical Release of Spring Brake see Pages 7-9 for Gold Seal/Midland brakes. Page 10 for Life Seal brakes.

**⚠ DANGER:** Failure to comply with all instructions for mechanical release may result in the forceful release of the spring which could CAUSE DEATH, SEVERE PERSONAL INJURY AND/OR PROPERTY DAMAGE.

2. If vehicle air pressure was used to aid in the caging process, exhaust the air pressure.
3. To prevent sudden release of service housing assembly and to facilitate rotation of air ports or mounting studs, the service push rod should be prevented from retracting by clamping the service push rod in place with vise grip pliers as shown (Figure 32a/b).
4. Remove service clamp/carriage bolt and rotate service housing (Figure 32a/b) or center body (Figure 33) to desired position.
5. Ensure that diaphragm is properly seated between the center body and housing lip and that the air ports are in the desired positions. When reinstalling the one-piece service clamp assembly (Figure 32a), torque the carriage nut to specifications listed in Table 4, Page 13. When reinstalling the two-piece service clamp assembly (Figure 32b), tighten each nut equally, alternating every other turn. Torque each carriage nut to specifications listed in Table 4, Page 13. **DO NOT strike clamp or unit with a hammer.**
6. Check carriage bolts and clamp assembly for proper seating around the center body and housing lip, and remove vise grip pliers previously clamped around the service push rod to prevent it from retracting.
7. Apply a maximum of 120 PSIG (8 BAR) air pressure to the service port and check seal for leakage by applying a water and soap solution to the service clamp area (No leakage is allowed).
8. Uncage park brake power spring. Refer to uncaging instructions: Pages 7-9 for Gold Seal/Midland brakes. Page 10 for Life Seal brakes.

**⚠ WARNING:** After reassembly, check for proper emergency and service brake operation. For brake adjustment, follow vehicle manufacturer's instructions.

FIG 32a

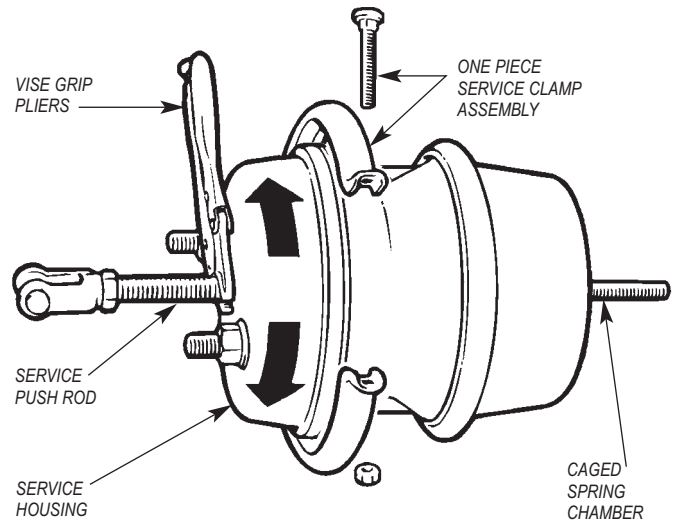

FIG 32b

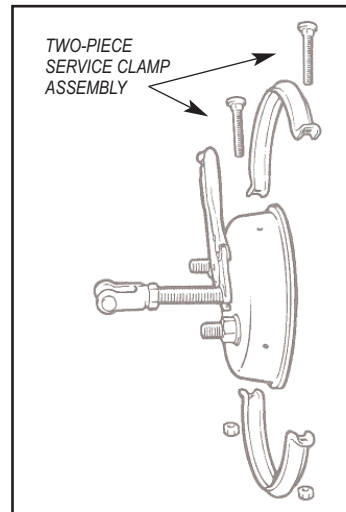
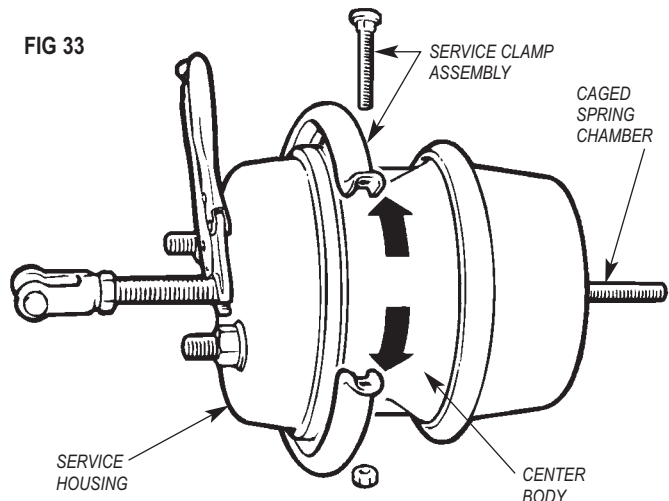

FIG 33



# Service Diaphragm Replacement

1. For Mechanical Release of Spring Brake see Pages 7-9 for Gold Seal/Midland brakes. Page 10 for Life Seal brakes.

**⚠ DANGER:** Failure to comply with all instructions for mechanical release may result in the forceful release of the spring which could CAUSE DEATH, SEVERE PERSONAL INJURY AND/OR PROPERTY DAMAGE.

2. If vehicle air pressure was used to aid in the caging process, exhaust the air pressure.
3. To prevent sudden release of the piggyback or service push rod assembly and to facilitate the installation of the new diaphragm, the service push rod should be prevented from retracting by clamping the service push rod in place with vise grip pliers as shown (Figure 34a/b).
4. Remove service clamp assembly and discard old diaphragm.
5. Inspect the service clamp assembly, the center body wall and lip, the housing, the service return spring and service push rod. If any structural damage is noted, replace with new part.
6. Wipe the surface push rod plate clean of any oil, grease or dirt.
7. Place the new service diaphragm in center body and center the housing over the diaphragm and center body (Figure 35).

**IMPORTANT:** It is recommended that a new service brake diaphragm be used when installing a new piggyback. DO NOT use a piloted diaphragm on the service side (a piloted "protrusion" diaphragm is designed to be used in the emergency spring chamber only). Use of a piloted diaphragm results in a reduction of stroke length.

8. Ensure that diaphragm is properly seated between the center body and housing lip and that the air ports are in the desired positions. When reinstalling the one-piece service clamp assembly (Figure 34a), torque the carriage nut to specifications listed in Table 4, Page 13. When reinstalling the two-piece service clamp assembly (Figure 34b), tighten each nut equally, alternating every other turn. Torque each carriage nut to specifications listed in Table 4, Page 13. **DO NOT strike clamp or unit with a hammer.**
9. Check carriage bolts and clamp assembly for proper seating around the center body and housing lip, and remove vise grip pliers previously clamped around the service push rod to prevent it from retracting.
10. Apply a maximum of 120 PSIG (8 BAR) air pressure to the service port and check diaphragm seal for leakage by applying a water and soap solution to the service clamp area (No leakage is allowed).
11. Uncage power spring (See instructions on Pages 7-9 for Gold Seal/Midland brakes. Page 10 for Life Seal brakes.).

**IMPORTANT:** After reassembly, check for proper emergency and service brake operation. If installed on vehicle, check brake adjustment by following vehicle manufacturer's instructions.

FIG 34a

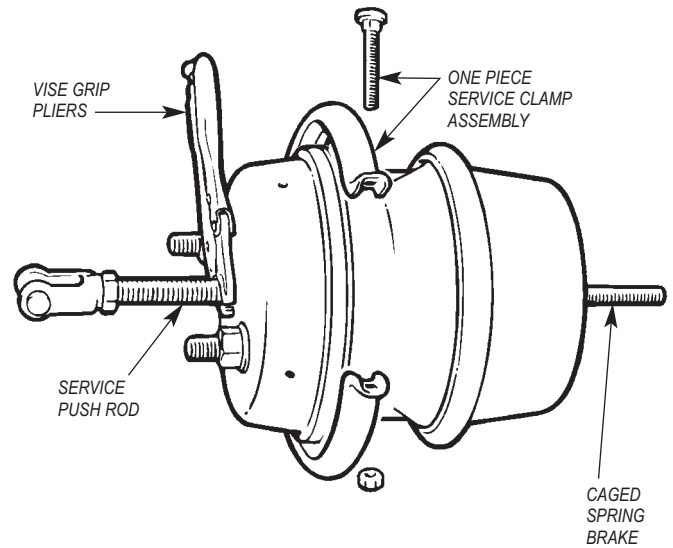

FIG 34b

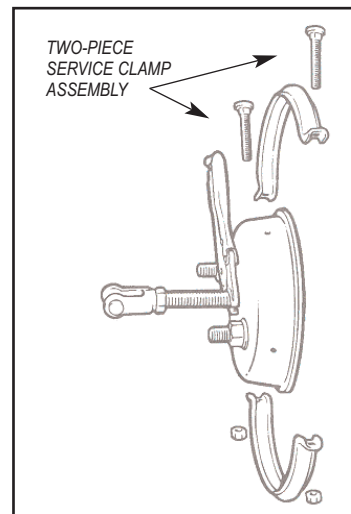
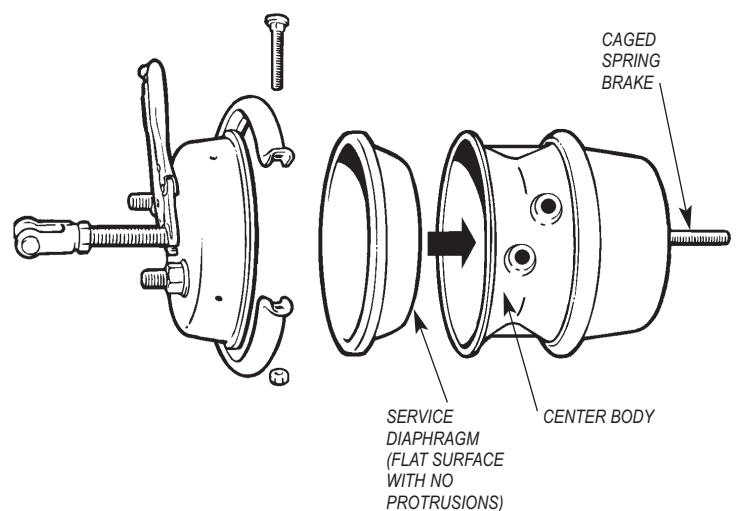

FIG 35



## Disarming Procedures: Piggyback and Combination Service/Spring Brakes

**⚠ DANGER:** A Piggyback or Combination Service/Spring Brake must be disarmed before disposal, or forceful release of the power spring may occur in the future without warning.

**NOTE:** A detailed drawing of the Safety Chamber is available free of charge upon request. Contact Haldex Engineering Department at 800-643-2374. (Drawing #110372 also on the web in Resources/Technical Literature)

1. Remove the caged Piggyback or Combination Service/Spring Brake from vehicle, after removal uncage the parking brake power spring.
2. Open the lid of the Safety Chamber and place the uncaged Piggyback or Combination Service/Spring Brake inside the chamber, close lid and lock hinges in place with bolts as shown (Figure 36).

**NOTE:** Service push rod may need to be cut in order to fit a Combination Service/Spring Brake into the Safety Chamber (Figure 36).

3. While wearing safety glasses, use an acetylene cutting torch and cut a 3" (76mm) diameter hole (Figure 37) out of the Spring Brake chamber wall through one of the openings in the Safety Chamber (Figure 36).
4. Once the power spring is exposed, use the acetylene cutting torch to cut the exposed spring in one or more places until the power spring pieces can be moved around inside the Spring Brake chamber with a long screwdriver or similar tool through the disarming chamber openings.
5. Once the power spring pieces can be moved around inside the Spring Brake chamber, the disarming process is complete and the piggyback can be removed from the Safety Chamber after it has cooled down. The unit can be submersed in water to cool it quickly.

**⚠ WARNING:** Cutting of the Spring Brake Chamber with an acetylene torch can result in harmful fumes. Do not breathe these fumes. All cutting should be done outside or in a well ventilated area. After cutting the chamber, submerge it in water to cool. If the disarmed unit is not cooled, it will emit additional fumes and it could start a fire if stored near combustible material.

FIG 36

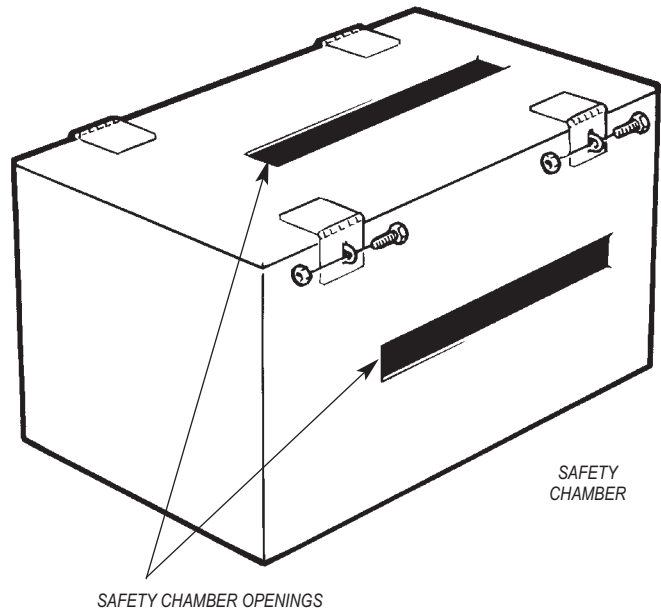
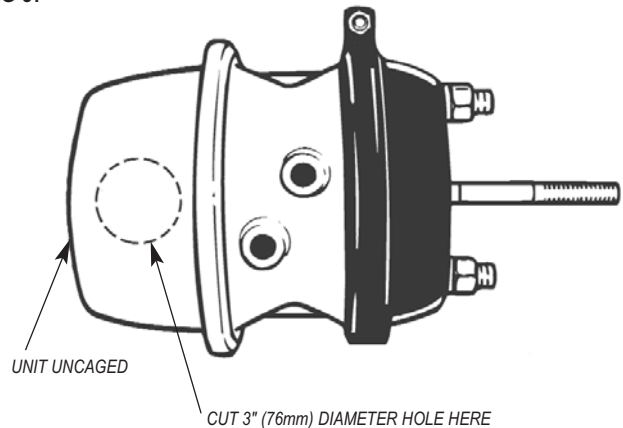

FIG 37



# Orange Alert Stroke Indicator Operation

**IMPORTANT:** All Haldex brake chambers are equipped with a stroke indicator which meets October 1994 FMVSS-121 requirements. Please read the following information carefully and familiarize yourself with the operation of this feature.

## WHAT IS A STROKE INDICATOR?

A Haldex Orange Alert stroke indicator is an orange knurled band located on the service push rod. This band is permanently embossed on the push rod and painted (Figure 38).

The orange band (stroke indicator) is normally inside the brake chamber (Figure 38) and will only start to protrude outside of the mounting face of the service housing when the spring brake or service chamber has only 20% of stroke remaining (Figure 39).

## HOW TO USE A STROKE INDICATOR

**IMPORTANT:** A stroke indicator is not intended to be used as the only indicator of when to adjust the brakes on a vehicle. For brake adjustment, follow vehicle manufacturer's instructions.

At the point where the leading edge of the stroke indicator is level with the mounting face of the service housing, as shown (Figure 39), the combination spring brake or service chamber has only 20% of available stroke remaining. (See Table 6 below).

When the stroke indicator becomes visible, maintenance is required. The brake may need adjustment, or it may require component replacement.

**IMPORTANT:** Depending on the location and type of mounting bracket used, it may be difficult to observe the stroke indicator's protrusion once the spring brake or service chamber has been mounted to the vehicle.

**IMPORTANT:** When disassembly of the Haldex Spring Brake is required, consult the Haldex "Instructions for Mechanical Release and Diaphragm Replacement." (See Pages 7-9 for Gold Seal/Midland brakes. Page 10 for Life Seal brakes.)

**TABLE 6 RECOMMENDED BRAKE RE-ADJUSTMENT STROKE**

TYPE (SIZE)	RATED STROKE		RE-ADJUST STROKE	
	INCHES	MILLIMETERS	INCHES	MILLIMETERS
9	1.75	44	1.38	35
12	1.75	44	1.38	35
16	2.25	57	1.75	44
16	2.50	64	2.00	51
20	2.25	57	1.75	44
20	2.50	64	2.00	51
20	3.00	76	2.50	64
24	2.25	57	1.75	44
24	2.50	64	2.00	51
24	3.00	76	2.50	64
30	2.50	64	2.00	51
30	3.00	76	2.50	64
36	3.00	76	2.25	57

FIG 38

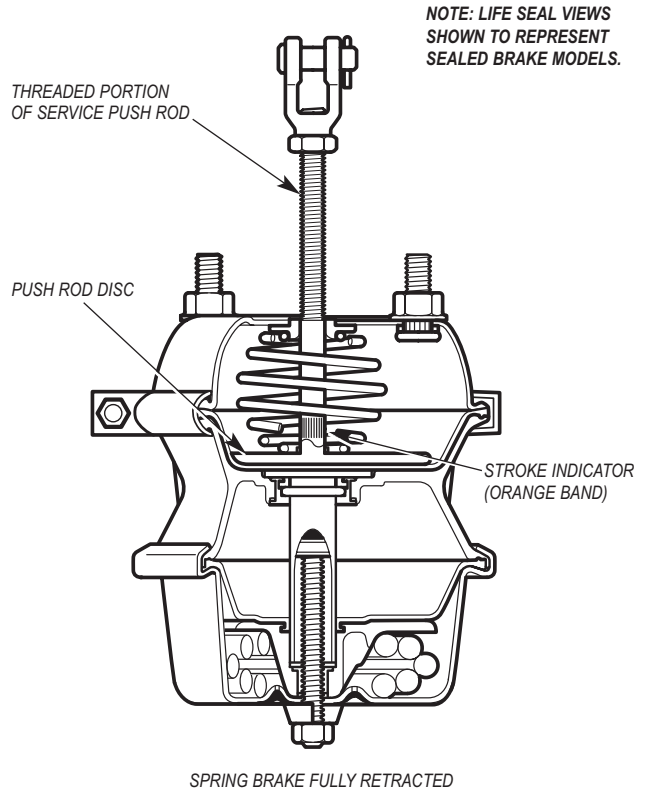
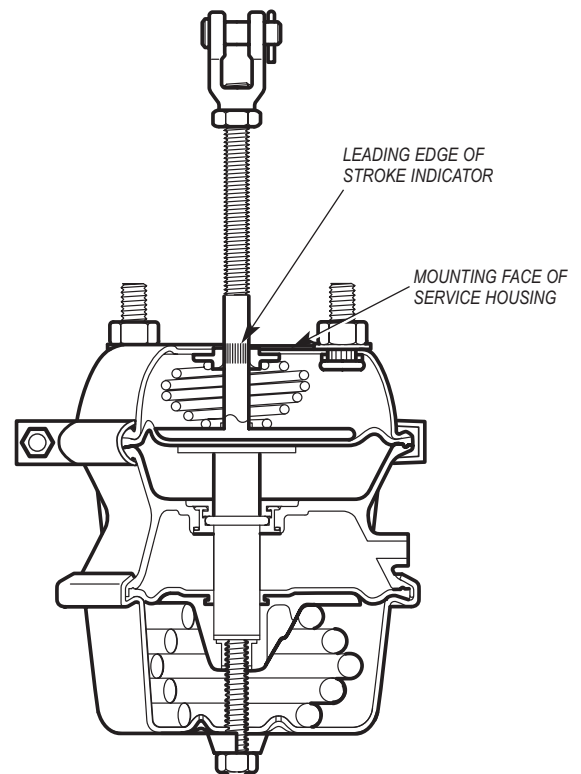

FIG 39



## Determining Warranty Status

### Actuator Date Code Change

For standardization and consistency, Haldex is modifying the date code format on all brake actuators produced after November 1, 2004. The date code will remain in the same location on all actuators.

The new date codes can be interpreted using the following information:

<b>Day of Year</b>	<b>Shift</b>	<b>Year</b>	<b>Location</b>
DDD Days running of the year	S A = First Shift B = Second Shift C = Third Shift	YY Two Digit Year	L A = Apodaca (Monterrey), Mexico K = Iola, Kansas

For example, a date code of 307A04A would translate to Tuesday, November 2, 2004, First Shift, Apodaca (Monterrey), Mexico.

Date codes on actuators built in Apodaca (Monterrey), Mexico (formerly Anchorlok) between June 1, 1990 and October 31, 2004, can be interpreted using the following information.

<b>Market</b>	<b>Day of Year</b>	<b>Year</b>	<b>Run No.</b>
O O = OEM D = Distributor	DDD Days running of the year	YY Two Digit Year	XX Production run

Date codes on actuators built in Iola, Kansas (formerly Midland) prior to November 1, 2004 can be interpreted using the following information.

<b>Day of Year</b>	<b>Shift</b>	<b>Year</b>	<b>Location</b>
DDD Days running of the year	S A = First Shift B = Second Shift C = Third Shift	Y Single Digit Year	L K = Iola, Kansas

If you have questions about this date code change or other Haldex Actuator technical issues, please contact your local Haldex Sales Professional.





## **Commercial Vehicle Systems**

**North American Sales Division  
Haldex Brake Products Corporation  
10707 N.W. Airworld Drive  
Kansas City, MO 64153-1215  
Phone: (816) 891-2470  
Fax: (816) 801-4198**

**North American Sales Division  
Haldex Limited  
525 Southgate Drive, Unit 1  
Guelph, Ontario CANADA N1G 3W6  
Phone: (519) 826-7723  
Fax: (519) 826-9497**

**[www.haldex.com](http://www.haldex.com) • [www.hbsna.com](http://www.hbsna.com)**